

- HOSEBED CAPACITIES
- ① 250' OF 2.50" TRU-ID HOSE
 - ② 250' OF 1.75" TRU-ID HOSE
 - ③ 600' OF 3.00" BIG-10 KEY HOSE
 - ④ 1000' OF 5.00" BIG-10 KEY HOSE

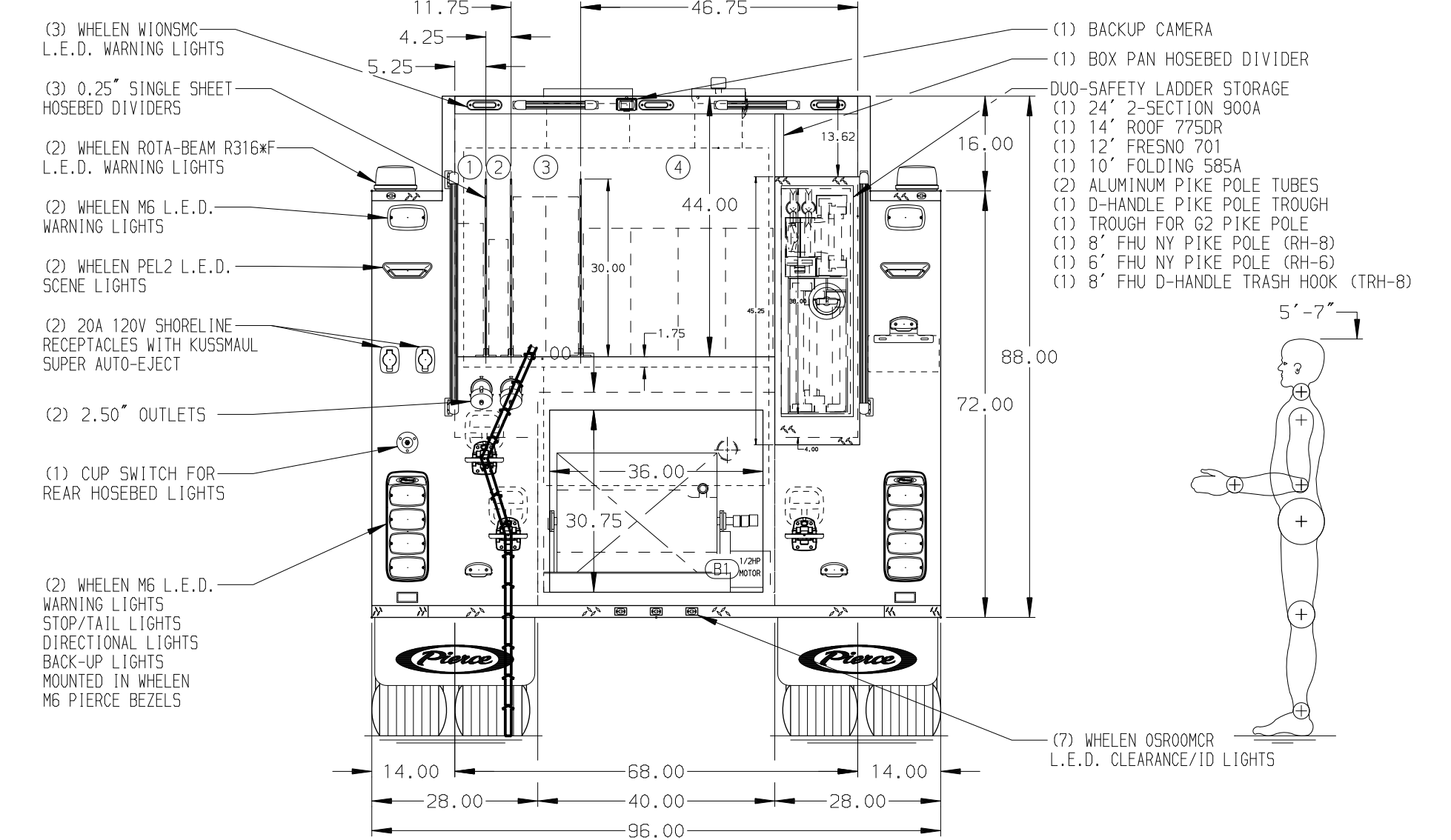
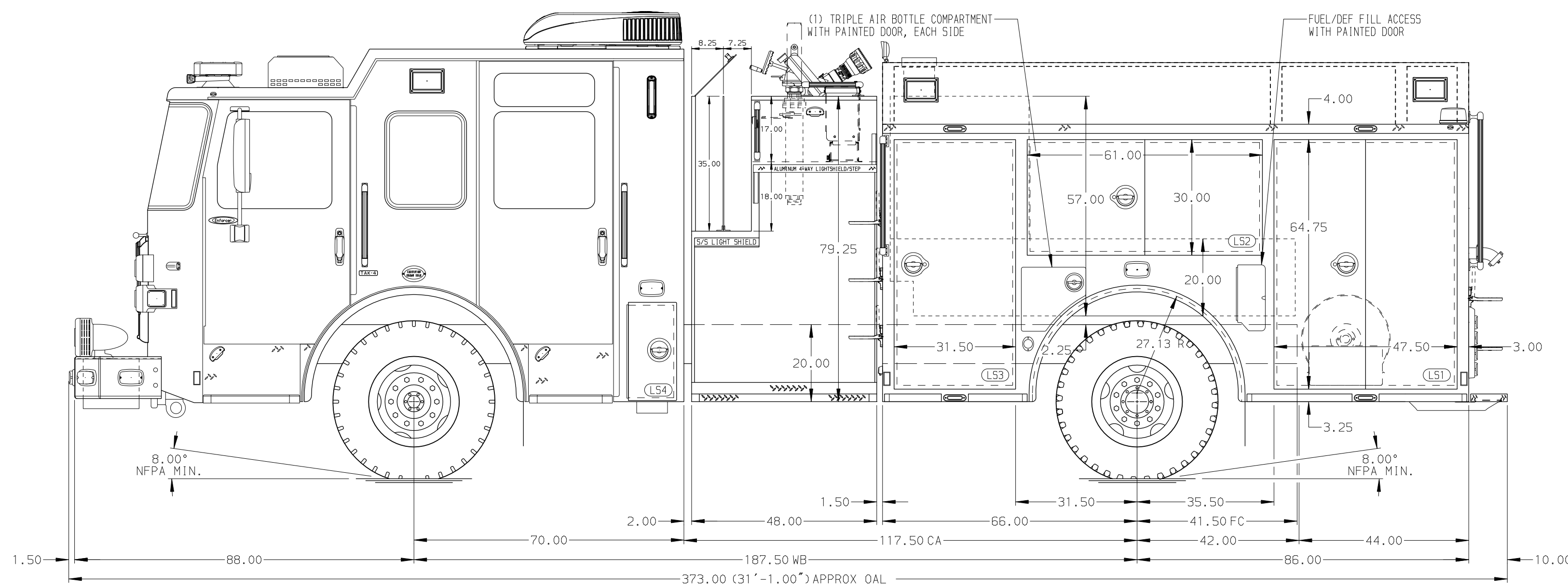
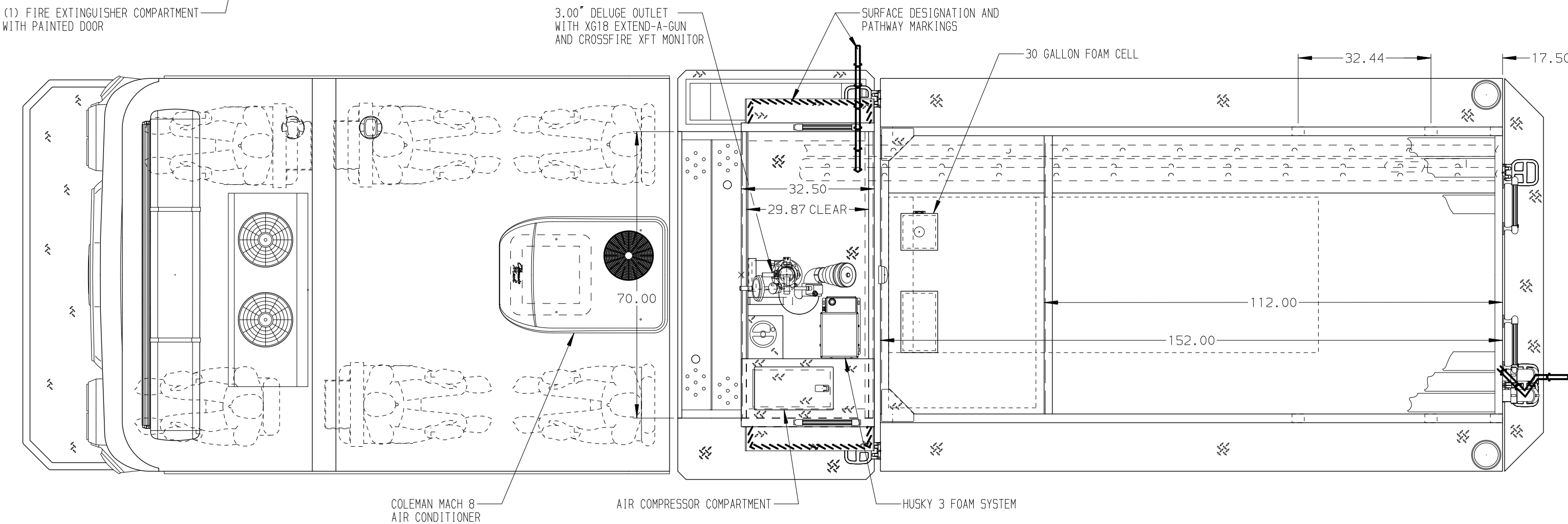

ALUMINUM BODY SIDE ROLL AND FRONTAL IMPACT PROTECTION

NOTE
DIMENSIONS SHOWN ARE APPROXIMATE AND ARE SUBJECT TO MINOR DEVIATIONS AS MAY OCCUR OR BE NECESSARY IN CONSTRUCTION. MINOR DETAILS NOT SHOWN.

- 1. DUAL L.E.D. LIGHT STRIPS LOCATED IN HOSE BED
- 2. WHEEL CHOCKS AND MOUNTING BRACKETS TO BE PROVIDED BY CUSTOMER
- 3. AIR INLET WITH DISCONNECT COUPLING IN THE DRIVER SIDE PUMP PANEL
- 4. BATTERY CHARGER LOCATED PER ORDER
- 5. BATTERY CHARGE INDICATOR LOCATED ON DRIVER SEAT RISER
- 6. ONE 15/20A 120V RECEPTACLE LOCATED IN CAB PER ORDER

REV	DATE	BY	CH	ENFORCER
13JAN26	LST	KBO		PIERCE
09SEP25	LST	KBO		MODEL

		JOB NO.	41496-01-08
		SCALE	1:24
TITLE 1500 GPM, 530G TANK, 500G WATER, 30G FOAM 152" 2G PUMPER, MUX		DATE	23JUL25
		DRAWN BY	LST
FOR DALLAS FIRE DEPARTMENT DALLAS, TEXAS		CHECKED BY	KBO
		DATE	25JUL25
DWG NO. 41496AD-SH1		SHEET SIZE	D
		SHEET NO.	1 OF 2