

BODY 107' ASL Aluminum Body PUC	TOTAL TANK CAPACITY 500 Gallon Poly Tank
COMPT, LEFT SIDE FRONT Full Height RollUp Forward	WATER CAPACITY 480 Gallons of Water
COMPT, LEFT SIDE REAR Full Height RollUp Rearward	FOAM CELL CAPACITY 20 Gallon Foam Cell
COMPT, RIGHT SIDE FRONT Full Height RollUp Forward	FOAM SYSTEM Husky 3 Single Agent Foam System
COMPT, RIGHT SIDE REAR Full Height RollUp Rearward	

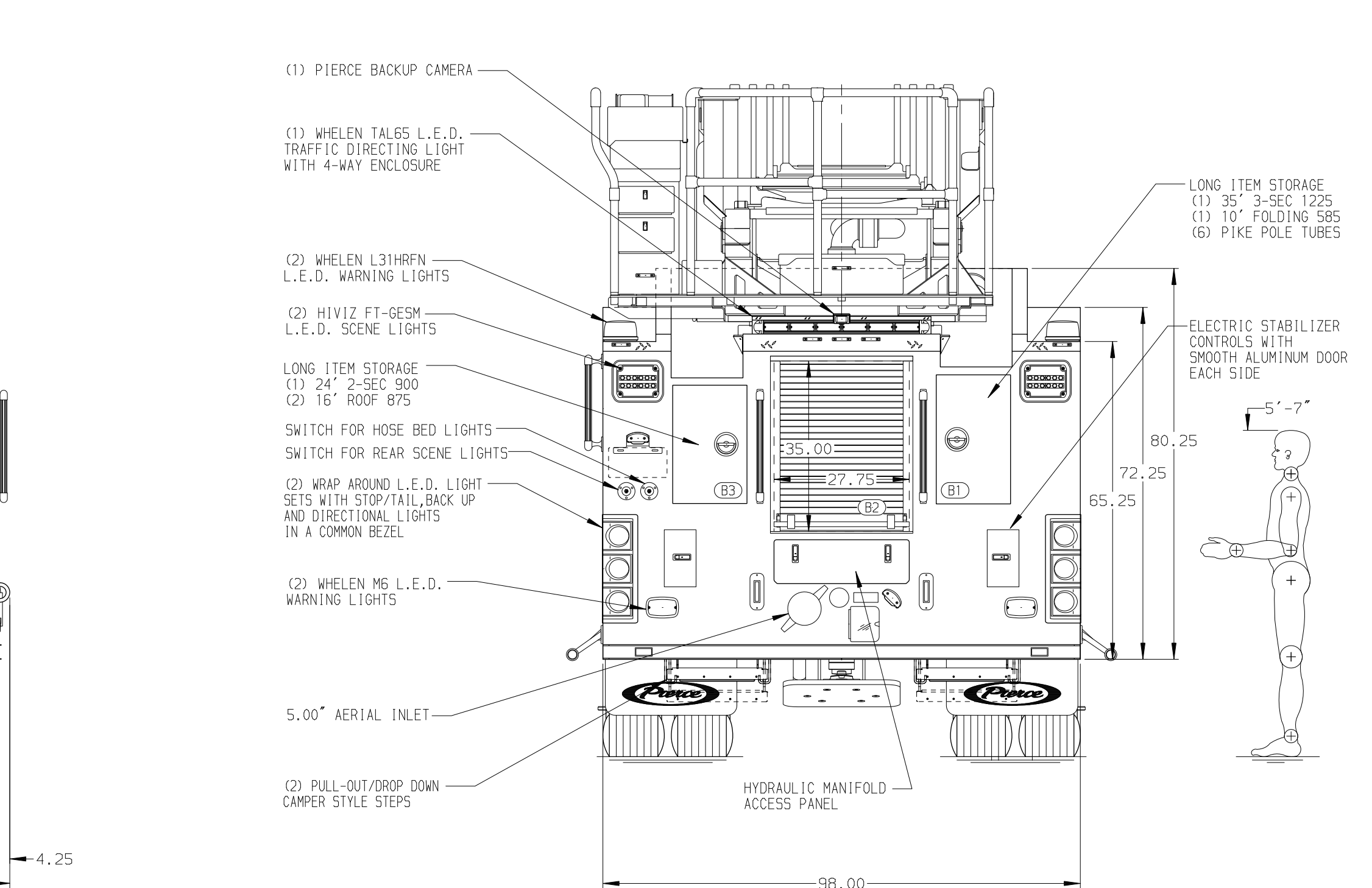

CHASSIS Enforcer Chassis, PUC 510 HP Paccor MX13 Engine	CAB 7010 Notched Enforcer Cab, PUC 19\"/>						
ELECTRICAL SYSTEM MUX TRANSMISSION ALLison 6th Gen, 4500 EVS P	AXLE, FRONT, CUSTOM 22,800 Lb TAK-4 Axle AXLE, REAR 33,500 Lb Meritor Axle	PUMPHOUSE Control Zone, PAL/PAP PUC PUMP 2000 GPM Pierce PUC	CROSSLAYS, 1.50" (2) 1.50", Poly Trays, 200' CROSSLAYS, 2.50" (1) 2.50", Poly Tray, 200'	SPEEDLAYS GENERATOR Generator Not Required	SAFETY Frontal Impact Protection	Pierce MANUFACTURING INC.	JOB NO. 41721
NOTE DIMENSIONS SHOWN ARE APPROXIMATE AND ARE SUBJECT TO MINOR DEVIATIONS AS MAY OCCUR OR BE NECESSARY IN CONSTRUCTION. MINOR DETAILS NOT SHOWN.	1. NO LIMITED RETRACTION REQUIRED 2. ONE 1.50 OUTLET WITH 2.00 PIPING AND SWIVEL LOCATED IN CENTER BUMPER TRAY 3. SHORELINE RECEPTACLE WITH KUSSMALL SUPER AUTO-EJECT LOCATED BEHIND CREW CAB DOOR 4. AIR INLET/OUTLET WITH DISCONNECT FITTING & 1/4 TURN VALVE IN THE DRIVER SIDE STEPMILL 5. BATTERY CHARGER LOCATED PER ORDER 6. BATTERY CHARGE INDICATOR LOCATED ON DRIVER SEAT RISER 7. AIR INLET/OUTLET WITH DISCONNECT FITTING & 1/4 TURN VALVE LOCATED ON DRIVER SIDE PUMP PANEL 8. TWO FLOOR MOUNTED SLIDE-OUT TRAYS LOCATED IN COMPARTMENTS PER ORDER 9. ONE SWING-OUT TOOLBOARDS LOCATED IN COMPARTMENT PER ORDER 10. TWO VERTICAL PARTITIONS LOCATED IN COMPARTMENTS PER ORDER	11. TWO RECEPTACLES LOCATED PER ORDER 12. TWELVE ADJUSTABLE SHELVES LOCATED IN COMPARTMENTS PER ORDER 13. 1500 GPM HIGH FLOW WATERWAY 14. TECNIO 4-SECTION RUNG LIGHTING AT AERIAL DEVICE 15. LIFTING EYE ROPE RESCUE ATTACHMENT AT AERIAL TIP				TITLE 107' ASCENDANT AERIAL LADDER AND BODY ASSEMBLY	SCALE 1:24
						FOR CITY OF GREENACRES GREENACRES, FL	DATE 01JUL25
						DWG NO. 41721AD	DRAWN BY ANZ
							CHECKED BY NAK
							17JUL25
							SHEET SIZE D
							SHEET NO. 1 OF 1