

<b>BODY</b> 107' ASL Tandem Axle Aluminum Body	<b>TOTAL TANK CAPACITY</b> 320 Gallon Poly Tank
<b>COMPT, LEFT SIDE FRONT</b> FH/FD Lap Forward w/o Chute	<b>WATER CAPACITY</b> 300 Gallons of Water
<b>COMPT, LEFT SIDE REAR</b> FH/FD Lap Rearward w/Angled Steps	<b>FOAM CELL CAPACITY</b> 20 Gallon Foam Cell
<b>COMPT, RIGHT SIDE FRONT</b> FH/FD Lap Forward w/Chute	<b>FOAM SYSTEM</b> Husky 3 Single Agent Foam System
<b>COMPT, RIGHT SIDE REAR</b> Full Height Lap Rearward w/Angled Steps	

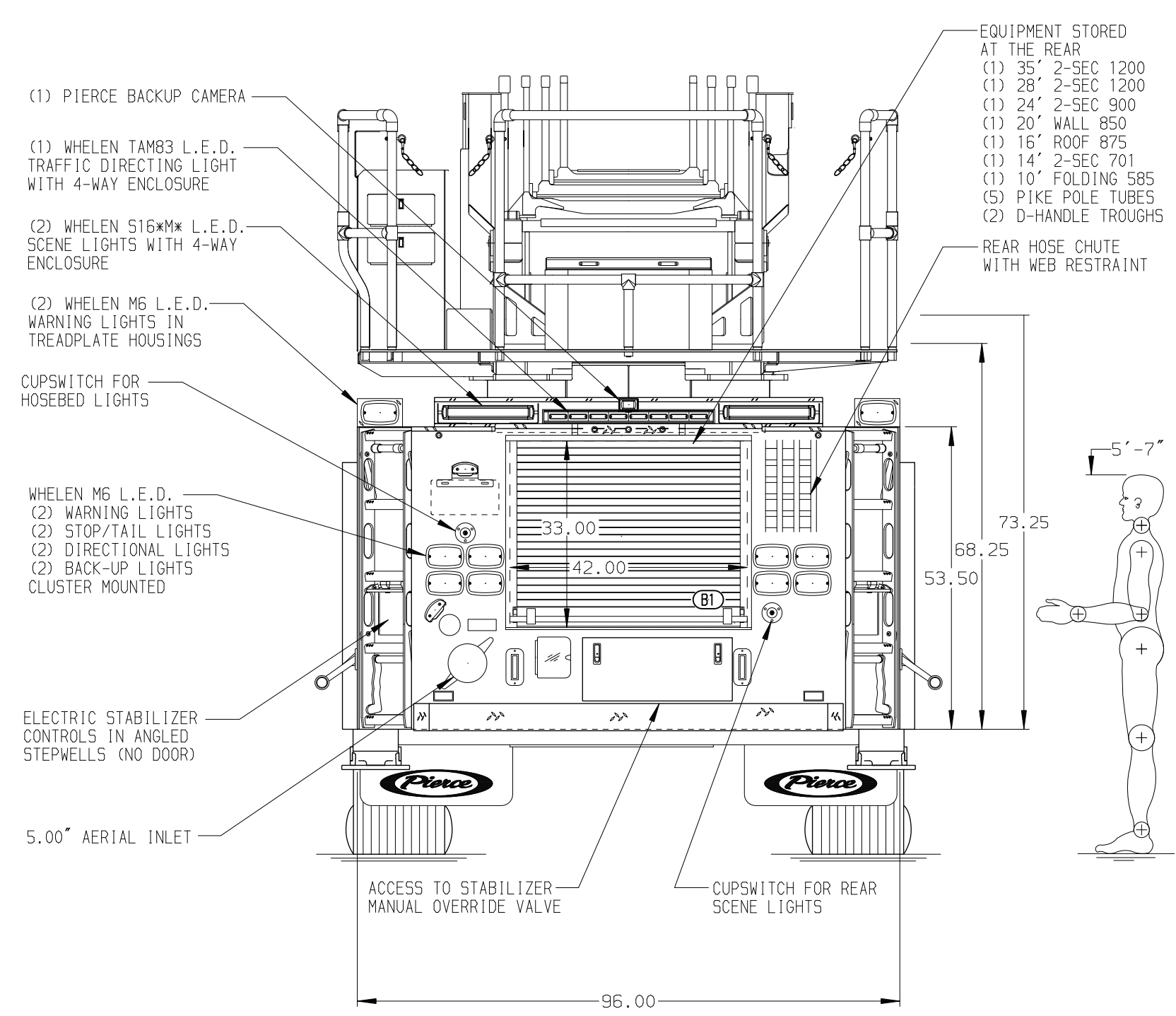

<b>CHASSIS</b> Enforcer Chassis 510 HP Paccor MX13 Engine	<b>CAB</b> 7010 Notched Enforcer Cab 16" Extended Painted Steel	<b>AXLE, FRONT, CUSTOM</b> 22,800 Lb TAK-4 Axle <b>AXLE, REAR</b> 44,000 Lb TAK-4 T3 Axle	<b>TRANSMISSION</b> Allison 6th Gen, 4500 EV5 P	<b>PUMPHOUSE</b> 50" Control Zone Side Mount 2000 GPM Waterous CSU	<b>CROSSLAYS, 1.50"</b> (2) 1.50" Standard Capacity <b>CROSSLAYS, 2.50"</b> (1) 2.50" Standard Capacity	<b>SPEEDLAYS</b> Speedlays Not Required <b>GENERATOR</b> Generator Not Required	<b>PIERCE MANUFACTURING INC.</b>	JOB NO. 42510
<b>NOTE</b> DIMENSIONS SHOWN ARE APPROXIMATE AND ARE SUBJECT TO MINOR DEVIATIONS AS MAY OCCUR OR BE NECESSARY IN CONSTRUCTION. MINOR DETAILS NOT SHOWN.								SCALE 1:24
1. NO LIMITED RETRACTION REQUIRED 2. DC POWER TO AERIAL TIP 3. SHORELINE RECEPTACLE WITH KUSSMALL SUPER AUTO-EJECT LOCATED ON DRIVER SIDE OF THE CAB 4. RECESSED AIR INLET/OUTLET WITH DISCONNECT FITTING & NEEDLE VALVE IN THE DRIVER SIDE STEPWELL 5. BATTERY CHARGER LOCATED PER ORDER 6. BATTERY CHARGE INDICATOR LOCATED ON DRIVER SEAT RISER 7. EIGHT ADJUSTABLE SHELVES LOCATED IN COMPARTMENTS PER ORDER 8. FOUR FLOOR MOUNTED SLIDE-OUT TRAYS LOCATED PER ORDER 9. TWO SLIDE-OUT TRAYS LOCATED IN COMPARTMENTS PER ORDER 10. ONE SWING-OUT TOOLBOARD LOCATED IN COMPARTMENT PER ORDER 11. TECNIO 4-SECTION RUNG LIGHTING AT AERIAL DEVICE 12. 1500 GPM HIGH FLOW WATERWAY 13. LIFTING EYE ROPE RESCUE ATTACHMENT AT AERIAL TIP 14. 3.00" RAISED AERIAL PEDESTAL								DATE
30JAN26 ANZ TDC 02SEP25 ANZ COS 24JUN25 ANZ TDC 29APR25 ANZ JLO								DATE
CHASSIS DATA MAKE PIERCE MODEL ENFORCER								DATE
TITLE 107' AERIAL ASCENDANT LADDER AND BODY ASSEMBLY FOR CITY OF GRIDLEY - BUTTE COUNTY GRIDLEY, CA DWG NO. 42510AD								DATE
REV DATE BY CH ENFORCER								DATE
SHEET SIZE D SHEET NO. 1 OF 1								DATE