

BODY
 100' LSL, Tandem Axle Aluminum Body
 COMPT, LEFT SIDE FRONT
 FH/FD RollUp Forward w/o Chute
 COMPT, LEFT SIDE REAR
 FH/FD RollUp and Lift-up Rearward
 COMPT, RIGHT SIDE FRONT
 FH/FD RollUp Forward w/o Chute
 COMPT, RIGHT SIDE REAR
 FH/FD RollUp and Lift-up Rearward

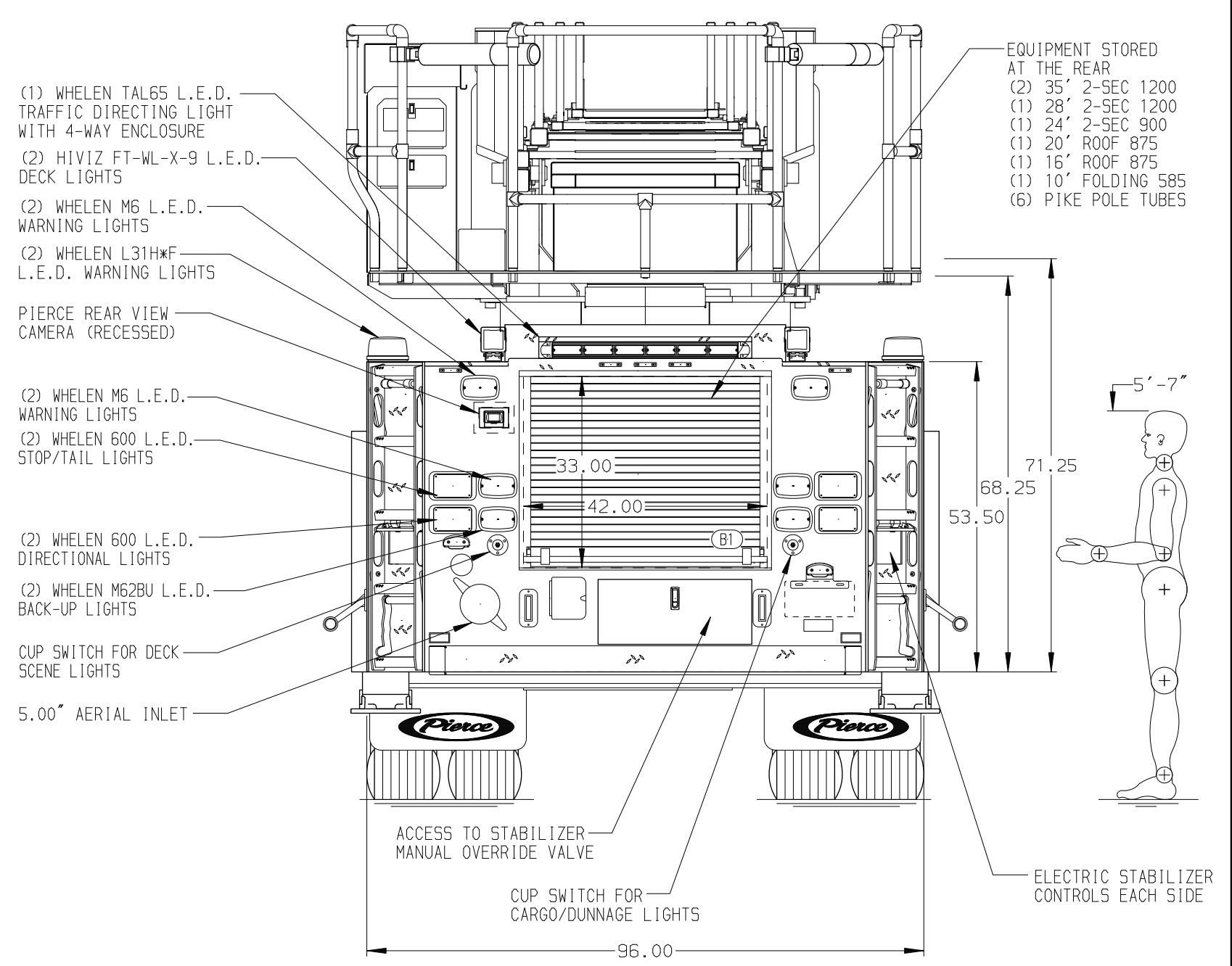
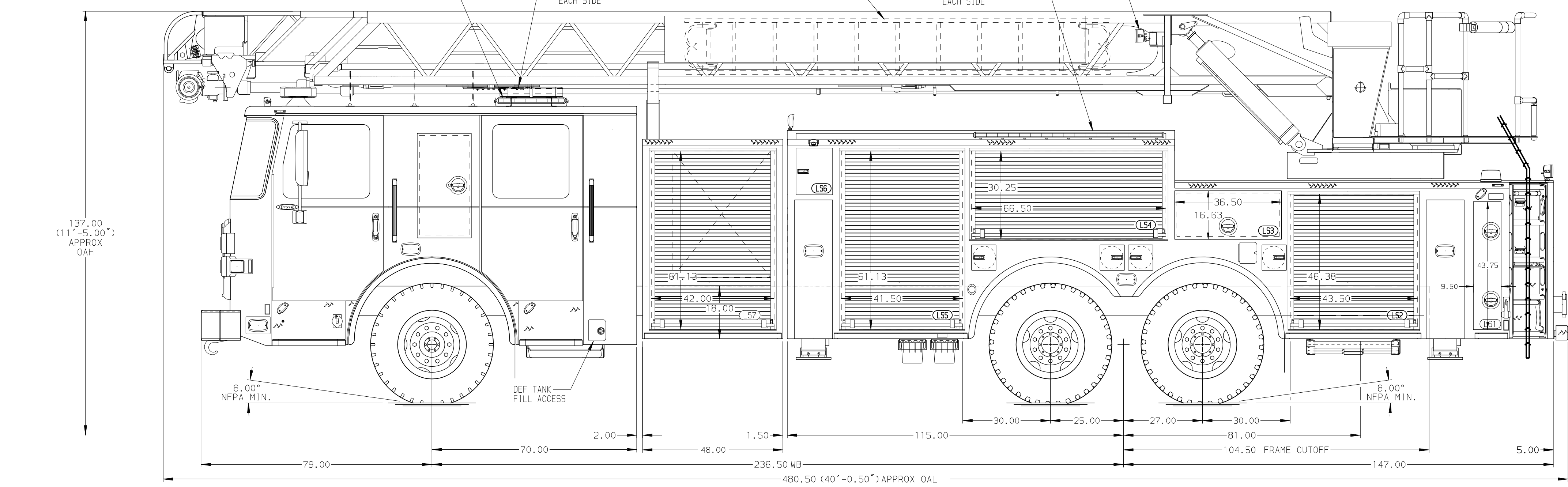
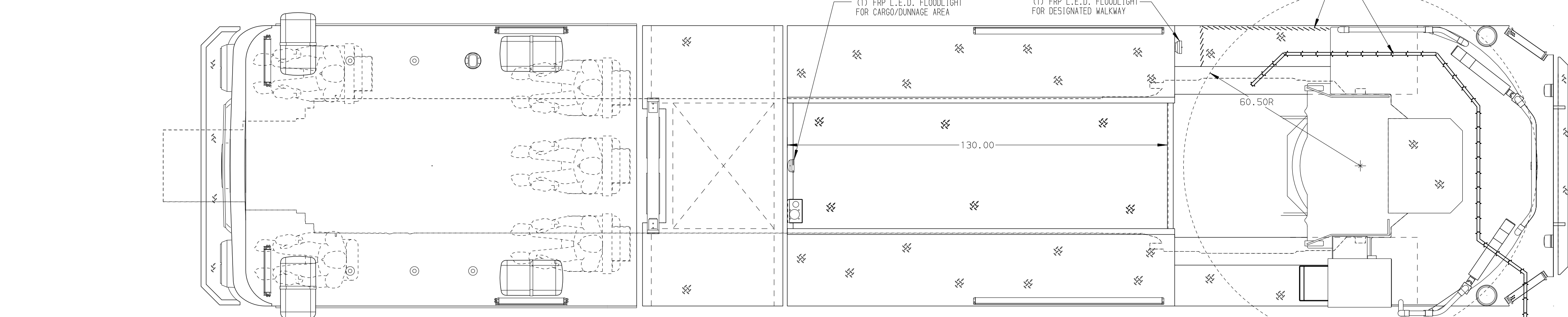

CHASSIS Enforcer Chassis ENGINE 510 HP Paccor MX13 Engine	CAB 7000 Enforcer Cab BUMPER 10" Extended Painted Steel	AXLE, FRONT, CUSTOM 21,500 Lb Meritor Axle AXLE, REAR 48,000 Lb Meritor Axle	TRANSMISSION Allison 6th Gen, 4000 EVS P GENERATOR Generator Not Required	COMPARTMENT-NO PUMP 48" Wide w/RollUp Door	SAFETY Side Roll & Frontal Impact Protection
--	--	---	--	--	--

NOTE
 DIMENSIONS SHOWN ARE APPROXIMATE AND ARE SUBJECT TO MINOR DEVIATIONS AS MAY OCCUR OR BE NECESSARY IN CONSTRUCTION. MINOR DETAILS NOT SHOWN.

- 14.00" AERIAL LIMITED RETRACTION
- SHORELINE STRAIGHT BLADE RECEPTACLE LOCATED IN DRIVER SIDE STEPWELL
- AIR INLET WITH DISCONNECT COUPLING LOCATED IN THE DRIVER SIDE STEPWELL FORWARD POSITION
- BATTERY CHARGER LOCATED BEHIND DRIVERS SEAT
- BATTERY CHARGE INDICATOR LOCATED ON DRIVER SEAT RISER
- EIGHT ADJUSTABLE SHELVES LOCATED IN COMPARTMENTS PER ORDER
- FOUR FLOOR MOUNTED SLIDE-OUT TRAYS LOCATED IN COMPARTMENTS PER ORDER
- ONE TOOLBOARD ADDED TO SLIDE-OUT TRAY LOCATED PER ORDER
- ONE CTECH THREE-DRAWER CABINET LOCATED IN COMPARTMENT PER ORDER
- ONE SLIDE-OUT 2-WAY TRAY LOCATED IN COMPARTMENT PER ORDER
- ONE RECEPTACLE STRIP LOCATED PER ORDER
- TWO BACK-WALL MOUNTED PEGBOARDS LOCATED IN COMPARTMENTS PER ORDER
- 5.00" RAISED AERIAL PEGSTAL
- LIFTING EYE ROPE RESCUE ATTACHMENT AT AERIAL TIP
- DC POWER TO AERIAL TIP
- TECNO 4-SECTION RUNG LIGHTING AT AERIAL DEVICE

		JOB NO.	44783
		SCALE	DATE
TITLE	100' LSL AERIAL LADDER AND BODY ASSEMBLY	DRAWN BY	ANZ
FOR	CITY OF RICHMOND RICHMOND, VA	CHECKED BY	JLO
DWG NO.	44783AD	SHEET SIZE	SHEET NO.
		D	1 OF 1

REV	DATE	BY	CH	ENFORCER
22SEP25	ANZ	AST	MAKE	
04AUG25	ANZ	J60	PIERCE	
29MAY25	ANZ	JLO	MODEL	